

Static Pressure Control

The Static Pressure Control (model SPC-2) is a fully programmable controller that provides extensive flexibility for your curtain or awning control needs. The SPC-2 automatically controls the pressure in a room by operating a curtain machine according to your programmed settings.

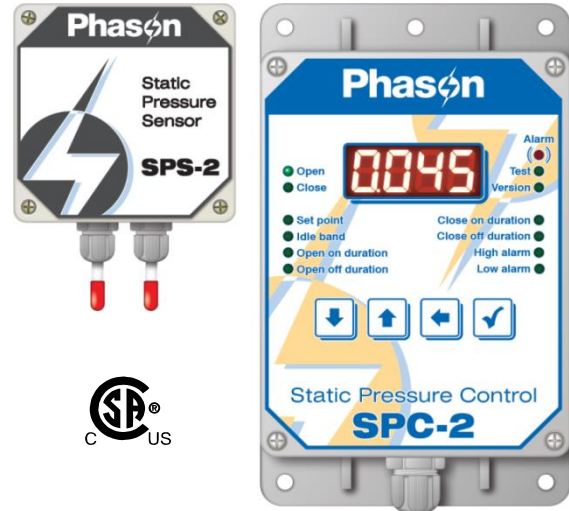

Controlling a curtain machine

- ◆ When the pressure is within the **Idle band** of the **Set point**, the SPC-2 maintains the curtain position.
- ◆ When the pressure rises above the **Idle band**, the SPC-2 opens the curtain for the **Open On duration**, and then pauses for the **Open Off duration**.
- ◆ After each **Off duration**, the SPC-2 checks the pressure and then either opens or closes the curtain (for the preset duration), depending on the pressure.

Features

- ◆ Automatic pressure-based control
- ◆ Two curtain relays (one open, one close)
- ◆ Programmable On and Off durations for the open and close relays, 1 to 900 seconds (up to 15 minutes)
- ◆ Programmable Idle band, 0.010 to 0.250 inWC
- ◆ Programmable High and Low pressure alarms
- ◆ Alarm relay (for external alarm system)
- ◆ Four-button keypad
- ◆ Four-character LED display
- ◆ Programming and status LEDs
- ◆ Manual override/test mode
- ◆ Power-failure settings protection
- ◆ Differential pressure sensor
- ◆ Rugged enclosures (corrosion resistant, water resistant, and fire retardant)
- ◆ cCSAus approval
- ◆ Limited warranty: 2 years for control, 90 days for sensor

Sensor ratings

- ◆ Pressure range: 0 to 0.25 inWC
- ◆ Output voltage: 0 to 4 VDC
- ◆ Supply voltage: 11 to 30 VDC, 12 VDC typical
- ◆ Supply current: 30 mA
- ◆ Operating range: 32 to 185°F (0 to 70°C)
- ◆ Storage range: -40 to 194°F (-40 to 90°C)
- ◆ Overpressure: 20 psi

Electrical ratings

- ◆ Input power 85 to 264 VAC, 50/60 Hz
- ◆ Open/close relays 15 A at 120/230 VAC, resistive load
1/2HP at 120 VAC, 1 HP at 230 VAC
- ◆ Alarm relay 0.4 A at 125 VAC; 2 A at 30 VDC, resistive load
0.2 A at 125 VAC; 1 A at 30 VDC, inductive load



If you are connecting any equipment that exceeds the ratings of the relays, you must install power contactors. For more information, read **Power contactors** on page 17.

Becoming familiar with the SPC-2

The main display shows the pressure and any alarm messages. The main display is what you see when you are not in a menu or settings display. Here are some things to know about the main display.

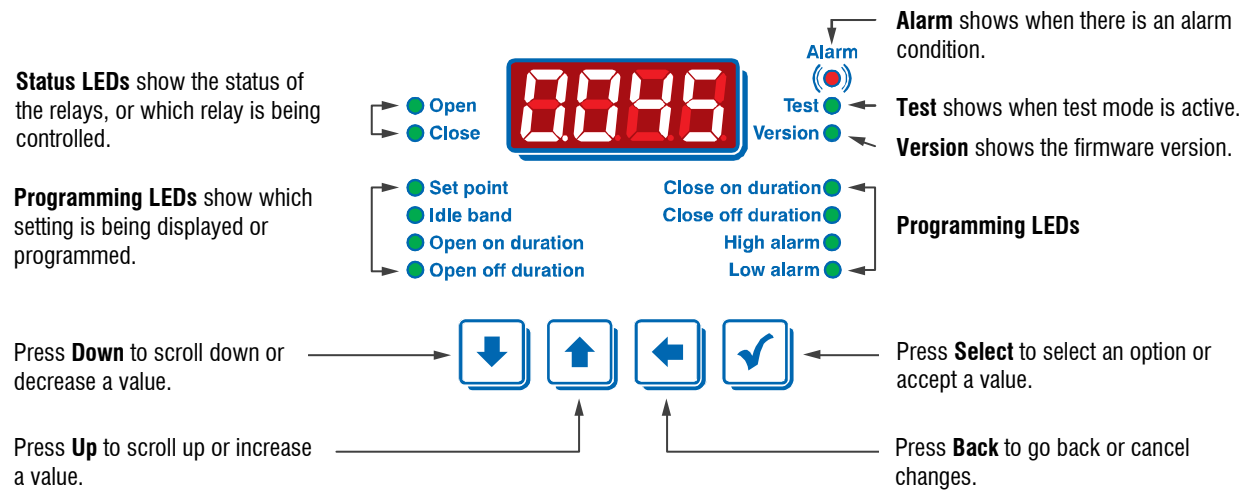

- ◆ When a relay is on, the status LED for that relay is lit.
- ◆ When there is an alarm condition, the display flashes between the alarm message and the current pressure.
For more information about alarms, read **Alarm settings and conditions** on page 10.
- ◆ When the control is in manual override mode, the **Open** and **Close** LEDs will blink three times and then stay off for one second.
For more information, read **Using manual override mode** on page 12

Main menu

When you are in the main menu, the display shows the menu items; the LEDs light up to show you which menu item is selected. Press **Up** or **Down** to move through the menu items.

Menu item	Display	Function
Open Close	CurT	Select automatic or manual override (open, close, or idle)
Alarm	ALAr	Switch the alarm relay on or off, <i>for testing only</i>
Test	tEST	Adjust the test pressure Restore the factory defaults
Version	UEr	Display the firmware version Update the firmware version
Set point	StPt	Adjust the curtain set point <i>Default: 0.045</i> <i>Range: 0 to 0.250 inWC</i>
Idle band	IdLE	Adjust the Idle band <i>Default: 0.060</i> <i>Range: 0 to 0.250 inWC</i>
Open on duration	On	Adjust the curtain open duration <i>Default: 20 seconds</i> <i>Range: 1 to 900 (up to 15 minutes)</i>
Open off duration	Off	Adjust the open idle duration <i>Default: 15 seconds</i> <i>Range: 1 to 900 (up to 15 minutes)</i>
Close on duration	C on	Adjust the close duration <i>Default: 20 seconds</i> <i>Range: 1 to 900 (up to 15 minutes)</i>
Close off duration	C off	Adjust the close idle duration <i>Default: 15 seconds</i> <i>Range: 1 to 900 (up to 15 minutes)</i>
High alarm	H, AL	Adjust the high alarm pressure <i>Default: 0.100</i> <i>Range: 0 to 0.250 inWC</i>
Low alarm	LoAL	Adjust the low alarm pressure <i>Default: 0.020</i> <i>Range: 0 to 0.250 inWC</i>

Installing the Static Pressure Control and sensor



- ◇ Read and follow all instructions when installing the control and equipment.
- ◇ Read **Electrical ratings** on page 2. Do not exceed the electrical ratings of the control.

Static Pressure Control layout

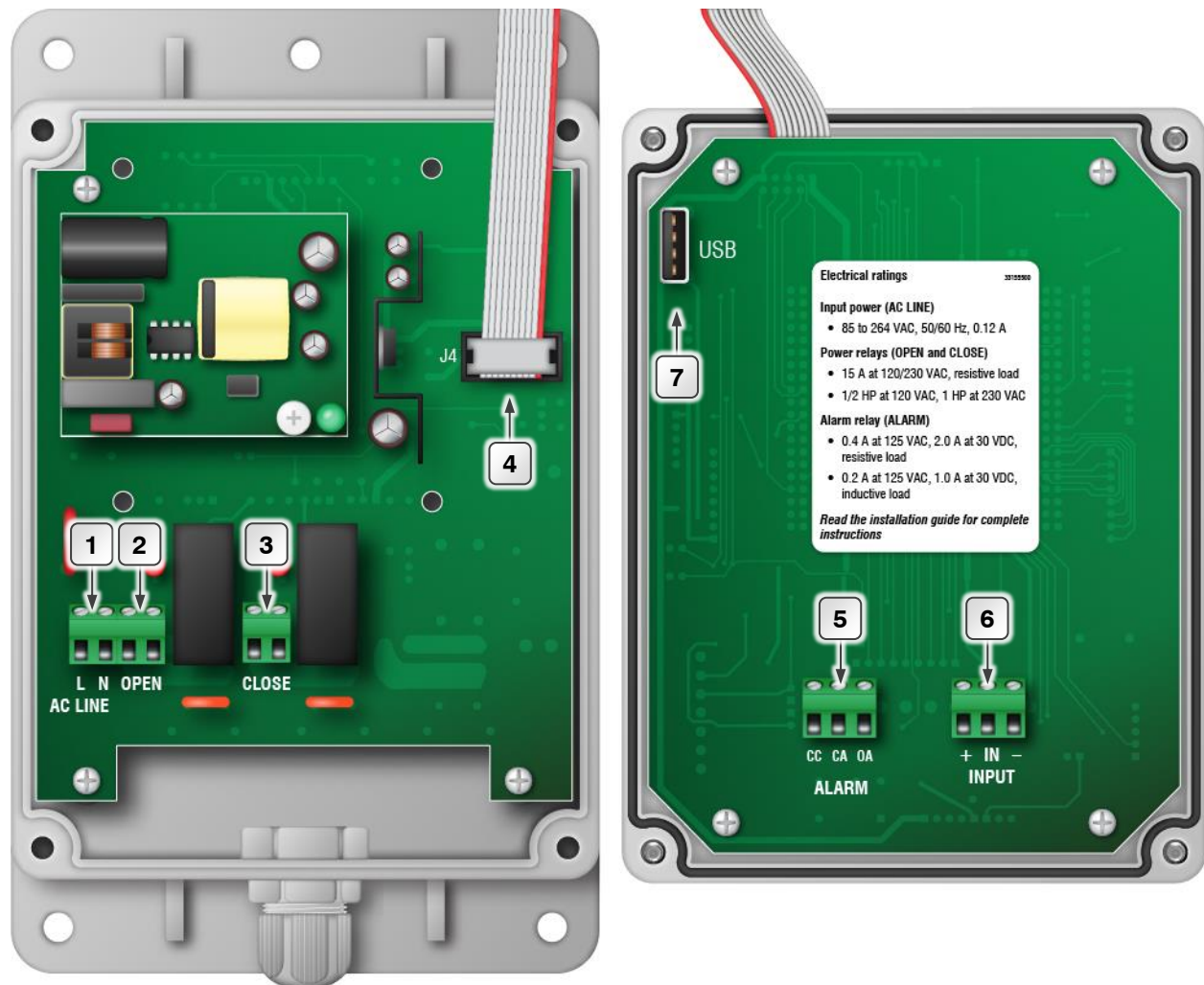

- 1 **Incoming power terminal:** connect the incoming power (85 to 264 VAC, 50/60 Hz) to this terminal. For more information, read **Connecting the power source** on page 5.

- 2 **Open and close relay terminals:** connect a curtain machine to these terminals. For more information, read **Connecting a curtain machine** on page 6.
- 3 **Connecting a curtain machine** on page 6.

- 4 **Display connector:** make sure the ribbon cable from the display is properly connected.

- 5 **Alarm relay terminal:** connect an external alarm system or siren to this terminal. For more information, read **Connecting an alarm system** on page 7.

- 6 **Input terminal:** connect the Static Pressure Sensor (SPS-2) to this terminal. For more information, read **Connecting the sensor wiring** on page 6.

- 7 **USB connection:** connect a USB memory stick to this connector to update the firmware. For more information, read **Updating the firmware** on page 15.

Static Pressure Sensor layout

- 1 **Output terminal:** connect a cable from here to the control. For more information, read **Connecting the sensor wiring** on page 6.
- 2 **Low pressure tube:** remove the red cover and then connect a tube to the room you are controlling. For more information, read **Connecting air tubes** on page 6.
- 3 **High pressure tube:** remove the red cover and then connect a tube to an area that is the same pressure as outside

Mounting the sensor

When mounting the Static Pressure Sensor, select a location where you can easily connect it to the control. Make sure you can run the pressure tubes to the room you are controlling and the reference pressure area (usually an attic or outside).

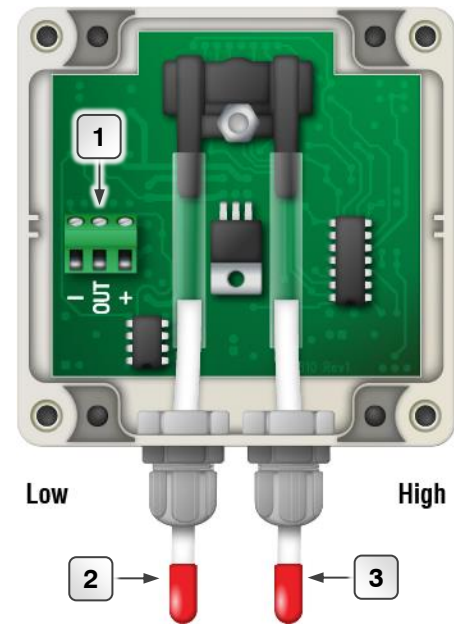

Mount the sensor less than 300 feet from the control.

Mounting the control

- ◆ Select a location for the SPC-2. Make sure you have enough wire and tubing to reach the equipment and area you want to control.
- ◆ Remove the screws from the front cover and then gently lift it off.
- ◆ Mount the enclosure to a wall using the four screws provided with the control. Insert the screws into the large holes in each corner of the box and then tighten.

Connecting the power source

Connect the incoming power (85 to 264 VAC, 50/60 Hz) as shown in the following diagram.



- ◇ Before connecting the incoming power, switch OFF the power at the source.
- ◇ Do not switch ON the power until you have finished all wiring and verified all equipment is properly connected and free of obstructions.

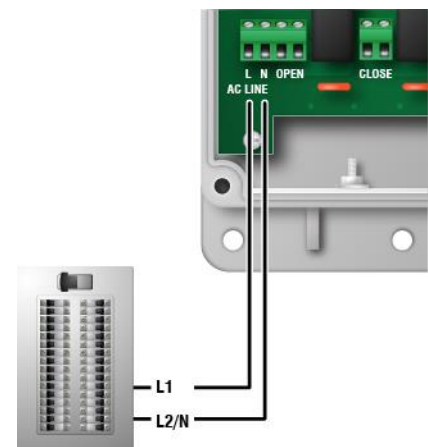

Connecting the sensor wiring

Routing the sensor wires in the same conduit as, or beside AC power cables, can cause electrical interference or erratic readings. Follow these guidelines when routing the sensor wires.

- ◆ Use **22 AWG** wire, **no more than 300 feet** in length.
- ◆ Do not run the wires in the same conduit as AC power cables.
- ◆ Do not run the wires beside AC power cables or near electrical equipment.
- ◆ When crossing other cables or power lines, cross them at a 90-degree angle.

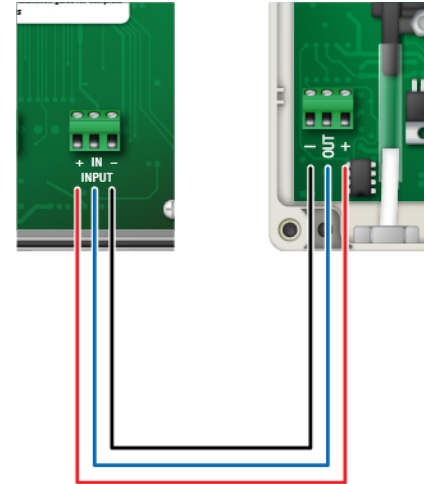

Connecting air tubes

Use PVC or similar flexible tubing with an inside diameter of 3/16 inch.

1. Remove the red caps from the existing air tubes.
2. Connect a tube to the ambient pressure port **LOW** and route it to the room you are controlling.
3. Connect a tube to the reference pressure port **HIGH** and route it to an area that is the same pressure as the outside.

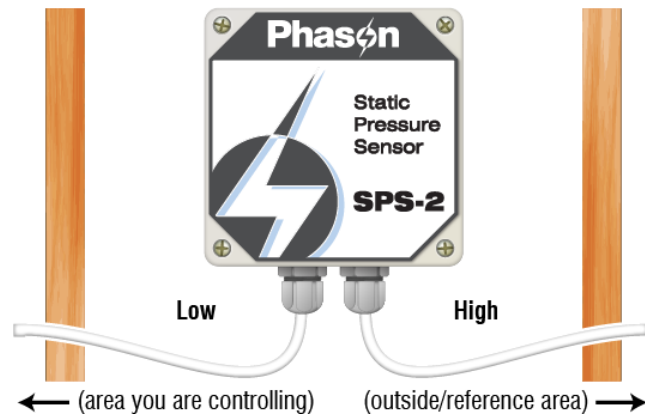

Do not blow or force air into the sensor tubes. The tubes are connected to highly sensitive equipment. Forcing air into a tube can easily damage the sensor.

Connecting a curtain machine

Curtains are usually controlled by equipment called curtain machines, sometimes referred to as *winches*. Connect the curtain machine to the control as shown in the diagram.

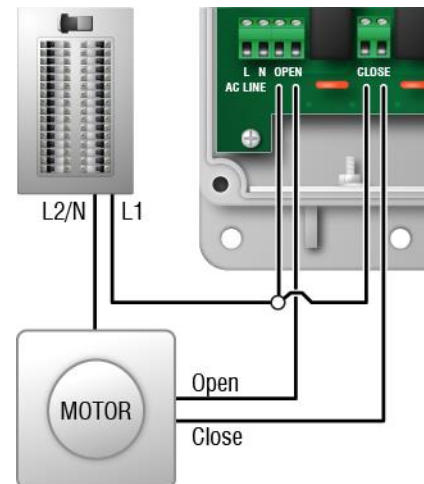

Connecting an alarm system

An alarm system can be a siren, an alarm panel, or an auto-dialer. See your alarm siren's installation guide for installation instructions and information about the type of system:

The descriptions for the alarm terminal are as follows: **CC**—common connection, **CA**—closed on alarm, **OA**—open on alarm.

To connect an alarm system

- ◆ If you are connecting the alarm system to a network of controls and your system uses a **normally open** connection (closes on alarm), connect the system as shown in the normally open diagram.

Join all the common (**CC**) connections together and all the closed-on-alarm (**CA**) connections together. The SPC-2 alarm relays must be in parallel with each other so any control can trigger the alarm system when an alarm condition occurs.

- ◆ If you are connecting the alarm system to a network of controls and your system uses a **normally closed** connection (opens on alarm), connect the system as shown in the normally closed diagram.

Join the alarm relays in a continuous loop. The SPC-2 alarm relays must be in series with each other so any control can trigger the alarm system when an alarm condition occurs.

Normally open system (closed on alarm)

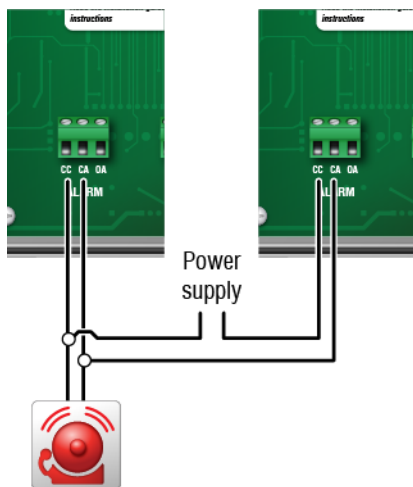

Normally closed system (open on alarm)

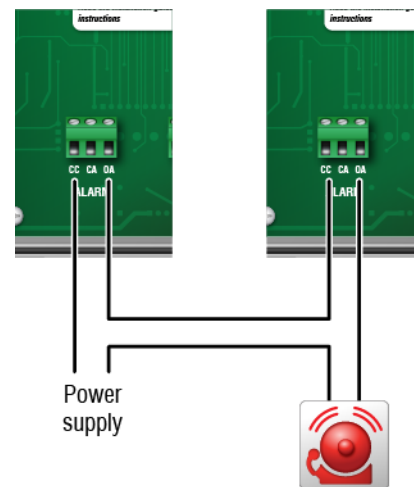

Finishing the installation

After you have finished connecting all equipment:

1. Make sure all wires are properly connected to the correct terminals.
2. Place the cover on the control.
3. Switch on the power to the control; it should display **8888** for three seconds, the version (for example, **v 100**) for three seconds, and then the pressure.

- ◆ If the display does not light up, go back to step 1.
 - ◆ If the alarm settings are not properly set, or the sensor is not properly connected, the display will likely show an alarm message. For more information, read **Alarm settings and conditions** on page 10.
4. Test the equipment. For more information, read **Testing and maintaining the SPC-2** on page 11
 5. Fasten the cover to the base.

Programming the Static Pressure Control

Before you begin programming the control, make sure it has power and that you have properly connected all equipment to the correct terminals.

How the curtain settings work

- ◆ **Set point:** the pressure at which the curtain holds its position
- ◆ **Idle band:** the buffer around the set point within which the curtain holds its position
- ◆ **Open on duration:** the duration the curtain opens during the open cycle
- ◆ **Open off duration:** the duration the curtain holds its position during the open cycle
- ◆ **Close on duration:** the duration the curtain closes during the close cycle
- ◆ **Close off duration:** the duration the curtain holds its position during the close cycle

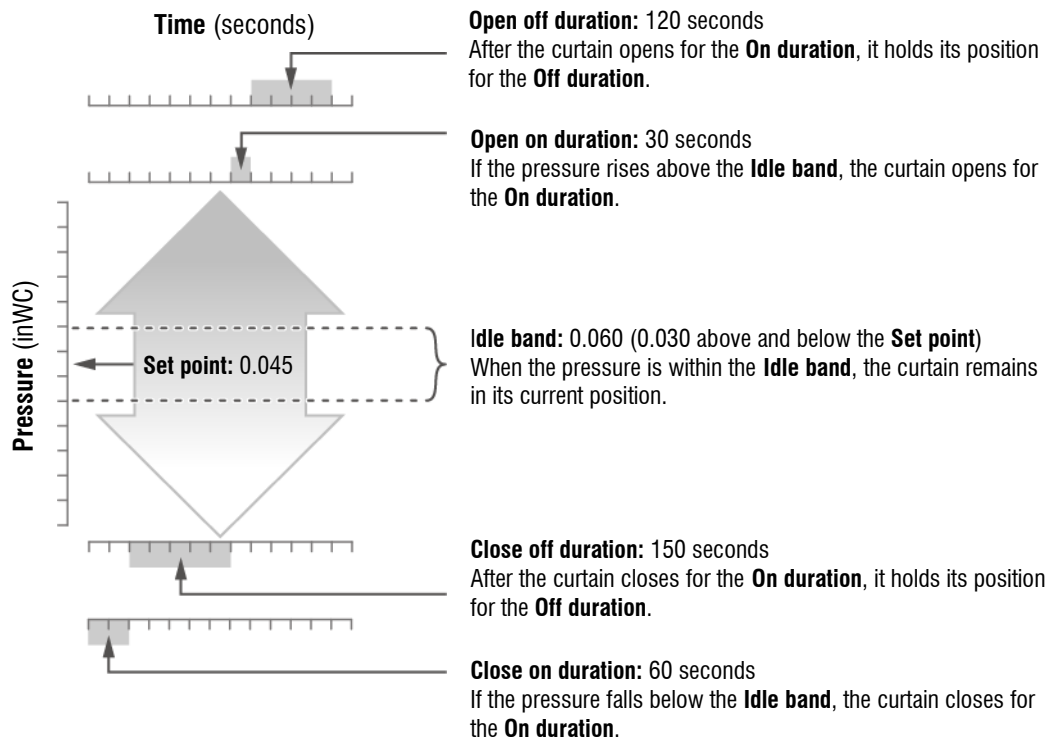

To program the Set point

Default: 0.045 Range: 0 to 0.250 inWC

1. Press **Down** until the display shows **SPt**.
2. Press **Select**.
The current setting (in degrees) displays and the **Set point** LED flashes.
3. Press **Up** or **Down** to adjust the setting and then press **Select**.
The change is saved and the display shows **SPt**.
4. Press **Down** to move to the **Open on duration**, or **Back** return to the main display.

To program the Open on duration

Default: 20 seconds Range: 1 to 900 (up to 15 minutes)

1. Press **Up** or **Down** until the display shows **On**.
2. Press **Select**.
The current setting (in seconds) displays and the **Open on duration** LED flashes.
3. Press **Up** or **Down** to adjust the setting and then press **Select**.
The change is saved and the display shows **On**.
4. Press **Down** to move to the **Open off duration**, or **Back** return to the main display.

To program the Open off duration

Default: 15 seconds Range: 1 to 900 (up to 15 minutes)

1. Press **Up** or **Down** until the display shows **OFF**.
2. Press **Select**.
The current setting (in seconds) displays and the **Open off duration** LED flashes.
3. Press **Up** or **Down** to adjust the setting and then press **Select**.
The change is saved and the display shows **OFF**.
4. Press **Down** to move to the **Close on duration**, or **Back** to return to the main display.

To program the Close on duration

Default: 20 seconds Range: 1 to 900 (up to 15 minutes)

1. Press **Up** or **Down** until the display shows **Cn**.
2. Press **Select**.
The current setting (in seconds) displays and the **Close on duration** LED flashes.
3. Press **Up** or **Down** to adjust the setting and then press **Select**.
The change is saved and the display shows **Cn**.
4. Press **Down** to move to the **Close off duration**, or **Back** to return to the main display.

To program the Close off duration

Default: 15 seconds Range: 1 to 900 (up to 15 minutes)

1. Press **Up** or **Down** until the display shows **COFF**.
2. Press **Select**.
The current setting (in seconds) displays and the **Close off duration** LED flashes.
3. Press **Up** or **Down** to adjust the setting and then press **Select**.
The change is saved and the display shows **COFF**.
4. Press **Down** to move to the **Idle band**, or **Back** to cancel and return to the main display.

To program the Idle band

Default: 0.060 Range: 0.010 to 0.250 inWC

1. Press **Up** or **Down** until the display shows **ILE**.
2. Press **Select**.
The current setting (in degrees) displays and the **Idle band** LED flashes.
3. Press **Up** or **Down** to adjust the setting and then press **Select**.
The change is saved and the display shows **ILE**.
4. Press **Down** to move to the **High alarm**, or **Back** to cancel and return to the main display.

Alarm settings and conditions



When there is an alarm condition, the alarm relay activates and the Alarm LED flashes. The display alternates between the ambient pressure and the alarm message. You cannot acknowledge the alarm until the condition has cleared.

When the condition goes away, the alarm relay deactivates and the Alarm LED switches off. The display continues to alternate between the pressure and alarm message until you acknowledge the alarm. To acknowledge an alarm, press **Select**.

There are two alarm conditions:

- ◆ **High pressure:** is when the pressure is above the high pressure alarm setting. You can adjust the high pressure alarm from the **Low alarm** value to 0.250.
- ◆ **Low pressure:** is when the pressure is below the low pressure alarm setting. You can adjust the low pressure alarm from 0 to the **High alarm** value.

Alarm messages

Message and description	Possible cause	Possible solution
 High pressure alarm	The ambient pressure is too high. The high pressure alarm setting is too low.	<ul style="list-style-type: none"> ◇ Increase the open on duration and/or decrease the open off duration to lower the pressure in the room. ◇ Increase the high pressure alarm setting. For more information, read To program the High alarm below.
 Low pressure alarm	The ambient pressure is too low. The low pressure alarm setting is too high.	<ul style="list-style-type: none"> ◇ Increase the close on duration and/or decrease the close off duration to increase pressure in the room. ◇ Decrease the low pressure alarm setting. For more information, read To program the Low alarm below.

To program the High alarm

Default: 0.100 Range: from the **Low alarm** to 0.250, or OFF

1. Press **Up** or **Down** until the display shows **Hi AL**.
2. Press **Select**.
The current setting (in degrees) displays and the **High alarm** LED flashes.
3. Press **Up** or **Down** to adjust the setting and then press **Select**.
The change is saved and the display shows **Hi AL**.
4. Press **Down** to move to the **Low alarm**, or **Back** and return to the main display.

To program the Low alarm

Default: 0.020 Range: 0.000 to **High alarm**, or OFF

1. Press **Up** or **Down** until the display shows **Lo AL**.
2. Press **Select**.
The current setting (in degrees) displays and the **Low alarm** LED flashes.
3. Press **Up** or **Down** to adjust the setting and then press **Select**.
The change is saved and the display shows **Lo AL**.
4. Press **Down** to move to **Open/Close**, or **Back** to return to the main display.

Testing and maintaining the SPC-2**Using pressure test mode**

Pressure test mode allows you to test your equipment and settings by simulating the pressure. In pressure test mode, you adjust the “test pressure”.

As you increase or decrease the test pressure, the relays operate according to their settings and the test pressure. This gives you an idea of how your system performs over a full range of pressures. The relays remain operating according to the test pressure until you exit test mode.



- ◇ When the SPC-2 is in pressure test mode, it operates the equipment according to the test pressure, not according to the measured pressure.
- ◇ The SPC-2 does not exit test mode automatically. When you are finished testing, press **Back** to exit test mode.

To use pressure test mode

1. Press **Up** or **Down** until the display shows **t E S t**.
2. Press **Select**.
The display shows **P r E S**.
3. Press **Select**.
The **Test** LED flashes and the display shows the test pressure. The SPC-2 is now in pressure test mode.
4. Press **Up** or **Down** to adjust the test pressure.
The SPC-2 operates the equipment according to the test pressure.
5. When finished, press **Back** to return the control to automatic mode. Press **Back** twice to return to the main display.

Testing the alarm

You can manually switch the alarm relay on and off so that you can test your alarm system.

To test the alarm

1. Press **Up** or **Down** until the display shows **AL Ar**.
2. Press **Select**.
The display shows **o F F** (off) and the **Alarm** LED flashes.
3. Press **Up** or **Down** to change the relay state.
4. When finished, press **Back** to return to the main menu. Press **Back** again to return to the main display.

Using manual override mode

Manual override mode allows you to override the automatic settings and manually control the curtain. You can open, close, or pause the curtain. Manual mode is also useful for testing equipment.

When the main display is showing and the curtain is in override mode, the **Open** and **Close** LEDs will blink three times and then stay off for one second.

To override the curtain

- ◇ There is a three-second delay when switching between Open and Close. This is to allow the motor to stop before switching directions.
- ◇ The SPC-2 remains in override mode until you exit; it does not exit automatically.

1. Press **Up** or **Down** until the display shows **Cur**.
2. Press **Select**.
The **Open** and **Close** LEDs blink rapidly.
 - ◆ If you are in automatic mode, the display shows **Auto**.
 - ◆ If you are in override mode, the display shows **Overd**.
3. Press **Up** or **Down** until **Overd** (override) displays.
4. Press **Select**.
The display shows **IDLE** (idle).
5. Press **Up** to switch between idle/stop and **OPEN** (open), or **Down** to switch between idle and **CLOSE** (close). Each time you press the button the curtain starts or stops moving.
6. Press **Select**.
The control returns to the main menu and the display shows **Cur**.
7. Press **Up** or **Down** to select a different menu item, or **Back** to return the main display.

To exit manual mode

1. Press **Up** or **Down** until the display shows **Cur**.
2. Press **Select**.
The relay LED(s) blink rapidly and the display shows **Overd**.
3. Press **Up** or **Down** until the display shows **Auto**.
4. Press **Select**.
The display shows **Cur**.
5. Press **Up** or **Down** to select a different menu item, or **Back** to return the main display.

Restoring the factory defaults

Setting	Default	Range
Set point	0.045	0.010 to 0.250 inches of water (inWC)
Open ON duration	20	1 to 900 seconds (s)
Open OFF duration	15	1 to 900 s
Close ON duration	20	1 to 900 s
Close OFF duration	15	1 to 900 s
Idle band	0.060	0 to 0.250 inWC
High alarm	0.100	Low alarm to 0.250 inWC
Low alarm	0.020	0.000 to High alarm

You can restore the default settings using one of two methods: the **power on method** or the **power off method**. The power on method is the easiest way to restore the factory defaults. If the power on method does not work, use the power off method.

To restore the factory defaults using the POWER ON method

1. Press **Up** or **Down** until the display shows **EEt**.
2. Press **Select**.
The display shows **PrES**.
3. Press **Up** or **Down** until the display shows **FACt**.
4. Press **Select**.
The **Test** LED flashes and the display shows **no**.
5. Press **Up** or **Down** until the display shows **YES**.
6. Press **Select** to restore the factory defaults.
The control resets, displays the version for a few seconds, and then displays the pressure.

To restore the factory defaults using the POWER OFF method



We recommend having someone assist you if using the power off method.

1. Switch off the power to the control.
2. Switch on the power to the control while holding the **Up** and **Down** buttons. Keep holding the buttons until **dEF** displays.
3. Release the buttons.
The control resets, displays the version for a few seconds, and then displays the pressure.

Displaying the firmware version

Firmware is the internal programming instructions of the SPC-2. It is much like an operating system or software on a computer. Just like an operating system, the firmware has a version. If you call technical support, the support agent might ask you for the firmware version.

To display the firmware version

1. Press **Up** or **Down** until the display shows **Ver**.
2. Press **Select**.
The display shows **dISP**.
3. Press **Select**.
The display shows the firmware version and the **Version** LED flashes.
4. Press **Back** twice to return to the main display.

Updating the firmware

At Phason, we constantly improve and add new features to our products. You can update the firmware in your SPC-2 as these improvements become available; all you need is a USB memory stick and a firmware update file.

You can update the firmware using one of two methods: the **power on method** or the **power off method**. The power on method is the easiest way to update the firmware. If, for some reason, the power on method does not work, use the power off method.

Getting a file

You can get a firmware update file from the Phason support forum at www.forum.phason.ca or the Phason website at www.phason.ca.

You need to copy the file to a USB memory stick (USB drive). The USB drive must be formatted as a **FAT32 file system**. To check if the USB drive is the correct format, insert it into your computer and then open Windows Explorer.

1. Right-click the USB drive.
2. Click **Properties**.
3. Make sure the file system is FAT32.
If the file system is not correct, you will need to format the drive as FAT32, or use a different drive that is the correct format.
4. Copy the update file to the root of the USB drive. The *root* of the drive means *not in a folder*.

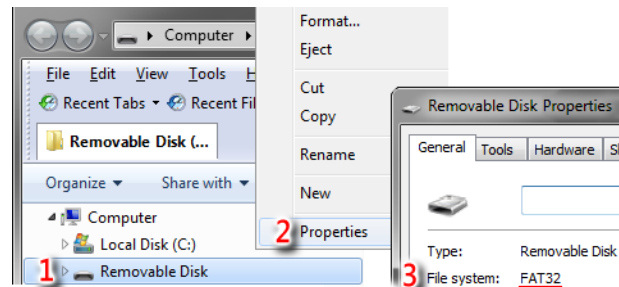

To update the firmware using the POWER ON method

1. Loosen the four cover screws and gently remove the cover from the control. Make sure not to disconnect the ribbon cable from the base; it must stay properly connected.
2. Insert the USB drive into the connector on the back of the cover.
3. Press **Up** or **Down** until the display shows **UEr**.
4. Press **Select**.
The display shows **d, SP**.
5. Press **Up** or **Down** until the display shows **UPdt**.
6. Press **Select**.
The display shows **n0** and the **Version** LED blinks.
7. Press **Up** or **Down** until the display shows **YES**.
8. Press and *hold* **Select** until the **Test** LED blinks rapidly.
9. Release the button.

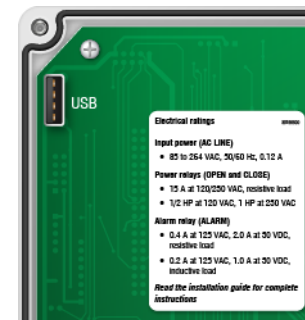

- ◆ While the **Test** LED is blinking rapidly, the firmware is updating. Updating can take up to 2 minutes.
 - ◆ After updating, the display shows **8888** for a few seconds, followed by the version number, and then the main pressure display.
10. When finished, remove the USB drive, verify the ribbon cable is properly connected, and then fasten the cover to the base.

To update the firmware using the POWER OFF method



We recommend having someone assist you if using the power off method.

1. Switch off the power to the control.
2. Loosen the four cover screws and gently remove the cover from the control. Make sure not to disconnect the ribbon cable from the base; it must stay properly connected.
3. Insert the USB drive into the connector on the back of the cover.
4. Switch on the power to the control while holding the **Select** button. Keep holding the button until the **Test** LED blinks rapidly.
5. Release the button.
 - ◆ While the **Test** LED is blinking rapidly, the firmware is updating. Updating can take up to 2 minutes.
 - ◆ After updating, the display shows **8888** for a few seconds, followed by the version number, and then the main pressure display.
6. When finished, remove the USB drive, verify the ribbon cable is properly connected, and then fasten the cover to the base.

Troubleshooting

If you see an error code and are not sure what it means, look it up in **Alarm settings and conditions** on page 10, and then follow the instructions to resolve the condition.

The following table lists some problems, possible causes, and possible solutions. If you are having a problem using the SPC-2, see if the problem is in the following table and then follow the directions for correcting the problem.

Problem	Possible cause	Possible solution
The power supply components are blown, or there are burn marks on boards and components. Motors and fans slow down or stop.	There has been a power surge, brownout, or power outage.	◇ Avoid the problem in future by providing proper voltage and protection for the control.
There is no power/display.	A circuit breaker at service panel is off or tripped. The incoming power wiring is incorrect.	◇ Reset the circuit breaker. ◇ Correct the wiring.
The display shows unusually high or low pressure.	The cable connected to the Static Pressure Sensor is providing a poor connection The sensor is not a Phason sensor. The Static Pressure Sensor is damaged.	◇ Check the cable connection and tighten it if necessary. ◇ Remove the sensor and then install a Phason sensor. ◇ Replace the sensor.
The curtain opens when it should close, or closes when it should open	The wiring is incorrect; the close and open wires are reversed.	◇ Correct the wiring. For more information, read Connecting a curtain machine on page 6.
The alarm relay is not operating the alarm system.	The alarm wiring is incorrect.	◇ Correct the wiring. For more information, read Connecting an alarm system on page 7.

Power contactors

Phason's 240-volt power contactors are heavy-duty relays that increase the load handling capability of control relays.

- ◆ **Power contactor relay (PC-240)**: includes power contactor relay and mounting hardware for easy mounting in an enclosure.
- ◆ **Power contactor kit (122-1)**: includes power contactor relay, on-off-auto switch and label, snubber filter (reduces electrical noise), and mounting hardware for easy mounting in an enclosure.
- ◆ **Power contactor unit (129-0)**: includes two power contactor relays, two on-off-auto switches, and two snubber filters, mounted in a large enclosure. The enclosure has room for two additional contactor relays or kits.

Parts and kits

If the display fails, you can replace it with a display kit. After replacing the display, you will need to program the control. If the bottom circuit board fails, you can replace it with a control kit.

- ◆ Pressure sensor **SPS-2**
- ◆ Display kit model **KSPC2-DISPLAY**
- ◆ Control kit model **KSPC2-CONTROL**

Static Pressure Control limited warranty

This warranty applies only to the Static Pressure Control (SPC-2). If you need warranty service, return the product and original proof of purchase to your dealer.

Phason Inc. (Phason) warrants the SPC-2 subject to the following terms and conditions.

This warranty is valid only to the original purchaser of the product, for two years from the manufacturing date. The manufacturing date is stated in the first eight digits of the serial number in the form year-month-day.

Phason hereby warrants that should the SPC-2 fail because of improper workmanship, Phason will repair the unit, effecting all necessary parts replacements without charge for either parts or labor.

Conditions

- ◇ Installation must be done according to our enclosed installation instructions.
- ◇ The product must not have been previously altered, modified, or repaired by anyone other than Phason.
- ◇ The product must not have been involved in an accident, misused, abused, or operated or installed contrary to the instructions in our user and/or installation manuals. Phason's opinion about these items is final.
- ◇ The person requesting warranty service must be the original purchaser of the unit, and provide proof of purchase upon request.
- ◇ All transportation charges for products submitted for warranty must be paid by the purchaser.

Except to the extent prohibited by applicable law, no other warranties, whether expressed or implied, including warranties of merchantability and fitness for a particular purpose, shall apply to the SPC-2. Any implied warranties are excluded.

Phason is not liable for consequential damages caused by the SPC-2.

Phason does not assume or authorize any representatives, or other people, to assume any obligations or liabilities, other than those specifically stated in this warranty.

Phason reserves the right to improve or alter the SPC-2 without notice.

Static Pressure Sensor limited warranty

This warranty applies only to the Static Pressure Sensor (SPS-2). If you need warranty service, return the product and original proof of purchase to your dealer.

Phason Inc. (Phason) warrants the SPS-2 subject to the following terms and conditions.

This warranty is valid only to the original purchaser of the product, for 90 days from the manufacturing date. The manufacturing date is stated in the first eight digits of the serial number in the form year-month-day.

Phason hereby warrants that should the SPS-2 fail because of improper workmanship, Phason will repair the unit, effecting all necessary parts replacements without charge for either parts or labor.

Conditions

- ◇ Installation must be done according to our enclosed installation instructions.
- ◇ The product must not have been previously altered, modified, or repaired by anyone other than Phason.
- ◇ The product must not have been involved in an accident, misused, abused, or operated or installed contrary to the instructions in our user and/or installation manuals. Phason's opinion about these items is final.
- ◇ The person requesting warranty service must be the original purchaser of the unit, and provide proof of purchase upon request.
- ◇ All transportation charges for products submitted for warranty must be paid by the purchaser.

Except to the extent prohibited by applicable law, no other warranties, whether expressed or implied, including warranties of merchantability and fitness for a particular purpose, shall apply to the SPS-2. Any implied warranties are excluded.

Phason is not liable for consequential damages caused by the SPS-2.

Phason does not assume or authorize any representatives, or other people, to assume any obligations or liabilities, other than those specifically stated in this warranty.

Phason reserves the right to improve or alter the SPS-2 without notice.

Service and technical support

Phason will be happy to answer all technical questions that will help you use your SPC-2. Before contacting Phason, check the following:

- ◆ Read this manual for information about the feature with which you are having trouble.
- ◆ If you are having a problem using your SPC-2, look in the **Troubleshooting** table on page 16, and then follow the directions to correct the problem.
- ◆ If you still have a problem with your SPC-2, collect the following information:
 - ◆ The serial number
 - ◆ Any messages displayed by your SPC-2
 - ◆ A description of the problem
 - ◆ A description of what you were doing before the problem occurred



- ◇ Phason controls are designed and manufactured to provide reliable performance, but they are not guaranteed to be 100 percent free of defects. Even reliable products can experience occasional failures and the user should recognize this possibility.
- ◇ If Phason products are used in a life-support ventilation system where failure could result in loss or injury, the user should provide adequate back up ventilation, supplementary natural ventilation, or an independent failure-alarm system. The user's lack of such precautions acknowledges their willingness to accept the risk of such loss or injury.

Phason Inc.
2 Terracon Place
Winnipeg, Manitoba, Canada
R2J 4G7

Phone: 204-233-1400
Fax: 204-233-3252

E-mail: support@phason.ca
Web site: www.phason.ca