

Static Pressure Sensor Installation Guide

The Static Pressure Sensor (SPS-2) is a differential pressure sensor designed to monitor the difference in pressure between the inside and outside of a building.

In ventilation systems, static pressure is the pressure exerted by the air inside a building, relative to the outside air pressure, when exhaust fans are turned on. Measuring and maintaining proper negative pressure allows the ventilation system to mix outside air with inside air more efficiently and effectively.

The SPS-2 is compatible with the Phason **Static Pressure Control (SPC-2)** and **Local Environment Monitor (LEM)**, and any third-party equipment capable of receiving 0 to 4 VDC input.

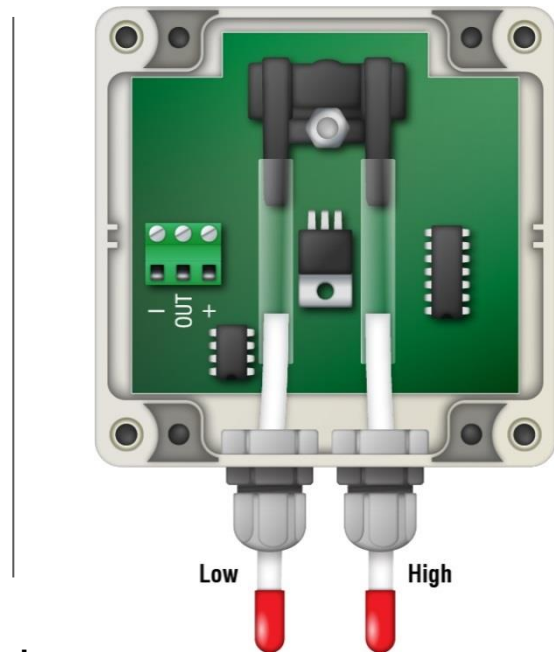

Ratings

- ◆ Pressure range: 0 to 0.25 inWC
- ◆ Output voltage: 0 to 4 VDC
- ◆ Supply voltage: 11 to 30 VDC, 12 VDC typical
- ◆ Supply current: 30 mA
- ◆ Operating range: 32 to 185°F (0 to 70°C)
- ◆ Storage range: -40 to 194°F (-40 to 90°C)
- ◆ Overpressure: 20 psi

Features

- ◆ Differential pressure sensor
- ◆ Easy installation and configuration
- ◆ Rugged enclosure (corrosion resistant, water resistant, and fire retardant)
- ◆ Limited warranty (90 days)

Mounting the sensor

When mounting the unit, select a location that allows you to easily connect it to the control, and allows you to run the pressure tubes to the room you are controlling and the reference pressure area (usually an attic or outside).



- ◇ Mount the sensor on a sheltered, vertical surface, with the strain reliefs facing down.
- ◇ Mount the sensor in a location that is no more than 300 feet away from the device you are connecting into, for example the Local Environment Monitor.
- ◇ Use a screwdriver to tighten the screws in the enclosure. Do not use a drill or over tighten the screws; this can crack the enclosure and ruin the watertight seal.

Routing sensor wires

Routing the sensor wires in the same conduit as, or beside AC power cables, can cause electrical interference or erratic readings. Follow these guidelines when routing the sensor wires.

- ◆ Do not run the wires in the same conduit as AC power cables.
- ◆ Do not run the wires beside AC power cables or near electrical equipment.
- ◆ When crossing other cables or power lines, cross them at a 90-degree angle.

Connecting air tubes



- ◇ Use PVC or similar flexible tubing with an inside diameter of 3/16 inch.
- ◇ Do not blow or force air into the sensor tubes. The tubes are connected to highly sensitive equipment. Forcing air into a tube can easily damage the sensor.

1. Remove the red caps from the air tubes.
2. Connect a tube to the ambient pressure port **LOW** and route it to the room you are controlling.
3. Connect another tube to the reference pressure port **HIGH** and route it to an attic or a room that is the same pressure as the outside.

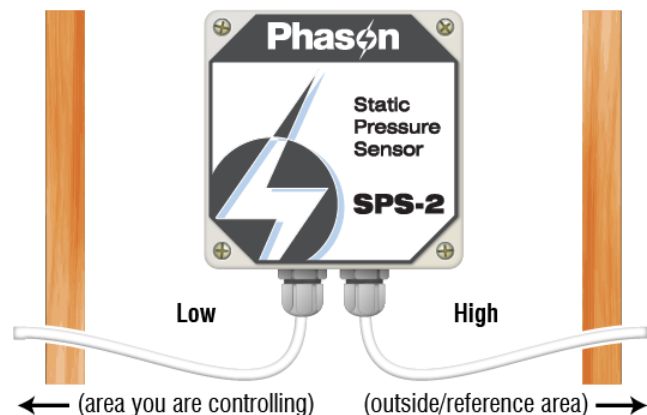

Connecting the wiring

- ◆ Use **22 AWG** wire, **no more than 300 feet** in length.
- ◆ When connecting the SPS-2 to a **LEM**, position the shunt on the jumper pins, as shown to the right.
- ◆ Connect the wires as shown to the right.
- ◆ For information about connecting the SPS-2 to a third-party control, read the installation guide for the specific control.

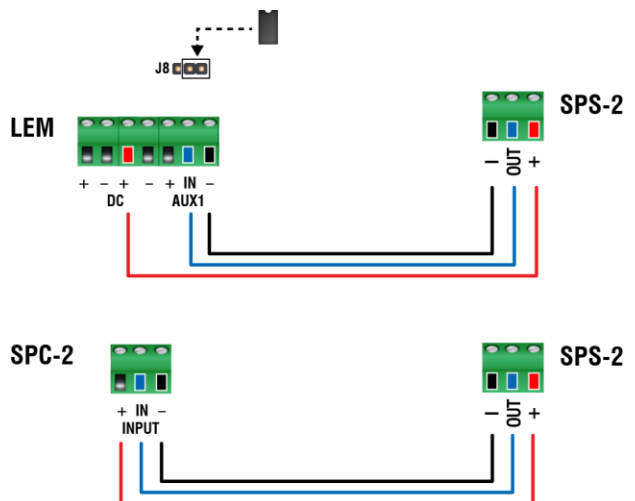

Phason Inc.
 2 Terracon Place
 Winnipeg, Manitoba, Canada
 R2J 4G7

Phone: 204-233-1400
 Fax: 204-233-3252

E-mail: support@phason.ca
 Web site: www.phason.ca